

# FACING BRICKWORK VENTILATED FAÇADES

# THE MANY FACES OF BRICKWORK



**We are specialized in facing brickwork and ventilated façades, technologies that we practice every day. We give body to residential complexes, shopping centres, social spaces. To conceptual works such as the labyrinth of Fontanellato and to entire urban areas, such as Treviso Due.**



Our work has already dressed projects by Architects Mario Botta, Gae Aulenti, Cino Zucchi, Amaro Isola, Pier Carlo Bontempi. A multi-faceted experience, just like the technical and aesthetic possibilities of brickwork.

## Everything about the facing walls

Quality of materials, skilled workmen, safety, on-time delivery. Our team takes care of your project from the preliminary study to the bricklaying. We give you comprehensive advice and support in the development phase of your project, so you can always find the most suitable solution to realize your idea, exactly as you imagined it.

## Handcrafted quality and technology

The quality of our works is given by the skills of our workmen. Our teams have formed over the years, and their number allows us to deal with works of any extension and type - like the 60.000 square meters of the facing walls in Treviso Due project. Always with a state of the art execution. Our processes and works are the synthesis between handcrafted practices and contemporary technologies.

## Ventilated façades. One technology, many pluses

Ventilated façades are the best solution to complete projects involving energy saving and a healthier environment. They ensure incredible durability, and in conjunction with the facing wall there is no limit to aesthetic designs. Ventilated façades are the present and the future of this industry, but we are already familiar with them. Since 1992, when we made our first work using this technology.

**1.000.000**  
square meters of built façades

**100.000**  
square meters of built façades every year

**150.000**  
square meters of built ventilated façades

# WE DRESS YOUR PROJECTS



**CANDELA**  
COSTRUZIONI

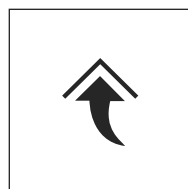

**VENTILATED FAÇADES**  
tradition meets technology

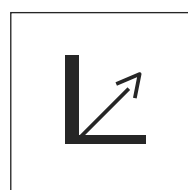

**FACING BRICKWORK**  
aesthetics and durability

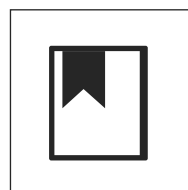

our partnership  
**TEAMWORK**  
every detail is checked and  
guaranteed by the best expert  
in the field.



quality of manpower  
**150 WORKERS**  
at your disposal

## Facing walls, in practice

Thanks to 150 workmen always at disposal, our teams bring the quality of their bricklaying in any kind of project. Together with the materials (bricks, mortars, support systems) and the technologies, their experience and skills are our best trademark and guarantee. If the bricklaying is the time when the project comes to life, all the previous steps are as much important.

## From design to realization

We coordinate with you right from the preliminary steps of the project. We give you a reference for everything related to the walls during the entire process that leads to the final building. We provide you with our experience and the experience of our partners to develop, define and put into practice your ideas.

Choice of bricks, choice of technology. We evaluate all aspects together. Implementation times, the relationship between quality and cost of materials, architectural balance, energetic functionality: the variables to consider are always numerous, and it is important to have an overview of the project.



# VENTILATED FAÇADES

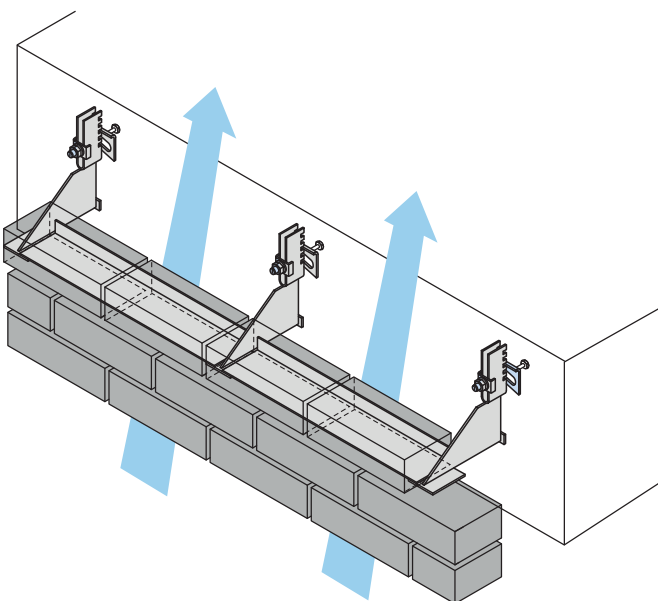

## Tradition meets technology

Ventilated façades bring many advantages, and are the perfect choice to suit a project with the needs of energy efficiency. They put together the well-known aesthetic qualities of the facing wall with thermal and acoustic insulation, healthiness and great functionality. And their durability is outstanding.

## What it is

The ventilated façade is a technology which uses the air and its movement as a natural insulation system. It is the most efficient solution to realize a wall system with excellent performances.

## How it works

The exterior layer of the ventilated façade is built with facing bricks, fixed with a support and hanging system. Hence the facing wall is secured to the building, but remains detached from it. The cavity created between the two surfaces communicates with the outside both at the top and at the bottom.

This allows the circulation of the air, creating the so called "chimney effect", that is the movement of air beneath the facade, due to the difference of temperature and moisture between the outside and the inside. The chimney effect has insulation properties.

## Air: a natural insulation system

Air is a natural and inexhaustible resource, which can be counted as one of the renewable sources that help us to satisfy our needs. Adopting the ventilated facades is not only a technological choice: it is a smart pick that brings efficiency and saving in constructions and it is consistent with the basic principles of energy responsibility.

## Cooperation

We are official partners of HALFEN for the supply and installation of ventilated facades with facing bricks. Since 2013 this cooperation has intensified, and allows us to give you an even better service.

# BRICKWORK

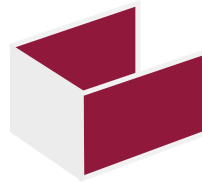

**CANDELA**  
COSTRUZIONI



An exciting characteristic of the brickwork is the possibility of creating an infinite variety of design.

The aesthetics of the brickwork and its integration with the other elements of the architectural language gives a strong personality to the projects, becoming one of their most recognizable signs.



# COOPERATION

The creation of facing walls is born from a complex mix of technology, skills, materials. Each element contributes to the final result.

This is the reason why we have collaborations with the most important brands in the industry. We work with them for the supply of materials and technical advice throughout the entire project cycle. In this way, every detail is checked and guaranteed by those who know him best.



official partners for the supply and installation of ventilated facades with facing bricks





via Giovanni Pesce, 14 \_ 20037 \_ Paderno Dugnano (Milano)  
T +39 0291084240 F +39 0291081000 info@candelacostruzioni.it

CANDELACOSTRUZIONI.IT

